

## Flame Photometric Detector Jet and Transfer Tube Assemblies

Description	HP Part No.	Qty.
1. O-ring, Kalrez, transfer tube	0905-1101	1
2. Transfer tube	19256-80550	1
3. Gigabore liner/ferrule assembly	19256-60590	1
4. Base assy, weldment	G1535-80510	1
5. Heater/sensor assembly	G1535-60620	1
6. Lower heater block	19256-20500	1
7. O-ring (Kalrez), jet cartridge	0905-1103	1
8. Jet cartridge	G1535-80500	1
9. Ferrule Vespel, 1/4 in. ID (Order no. 5080-8774)	0100-1061	1
10. Nut, brass, 1/4 in.	0100-0056	1

Flame Photometric Detector Jet and Transfer Tube Assemblies

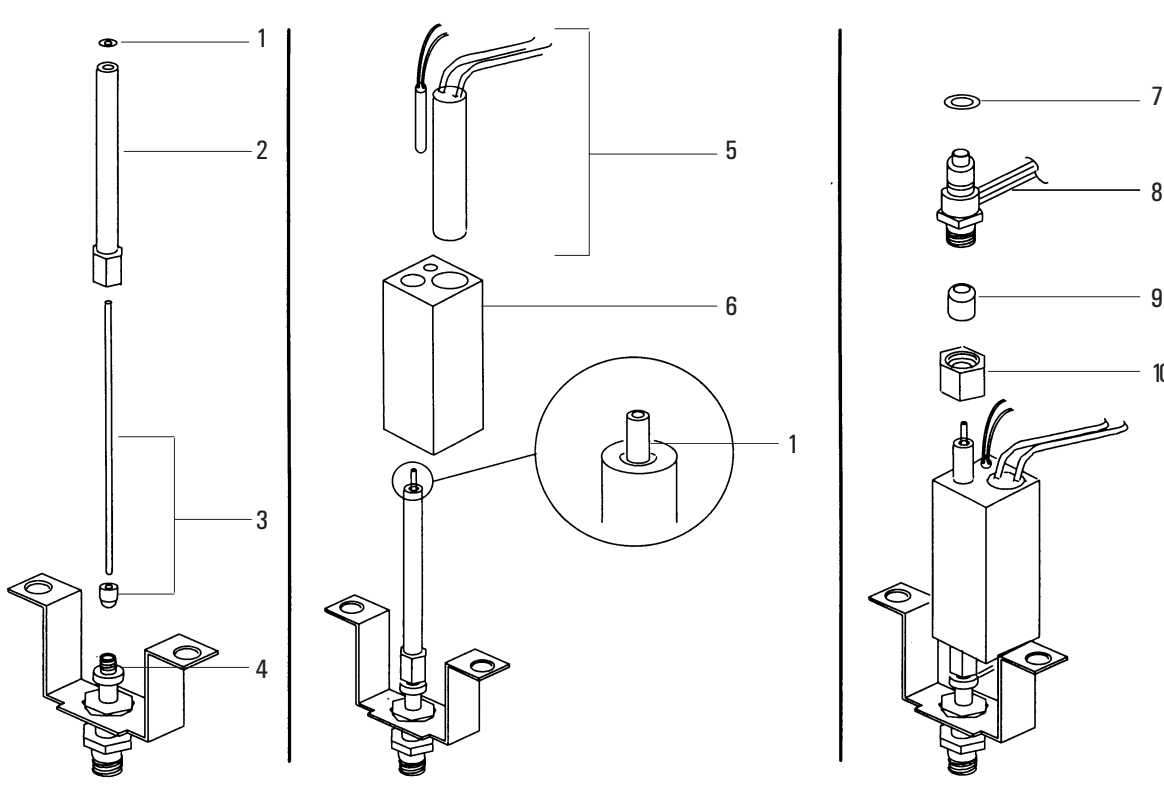

Figure 1320-12 Exploded Diagram of the Jet and Transfer Tube Assemblies

## Flame Photometric Detector PMT and Bracket Assemblies

Description	HP Part No.	Qty.
1. Heater/sensor assembly	G1535-60610	1
2. Photomultiplier Tube (PMT)	G1535-80050	–
3. O-ring	0905-1099	–
4. PM tube and housing assembly	19256-60510	1
5. Main bracket	G1535-00010	1
6. Chimney, back	G1535-00020	1
7. Chimney, front	G1535-00030	1
Filters		1
Sulfur mode (not shown)	19256-80000	
Phosphorus mode (not shown)	19256-80010	